

INTEGRATED ARC PROTECTION CONCEPTS

By Juha Arvola, Olavi Vahamaki, VAMP Ltd.

SUMMARY

The paper describes the general characteristics of electric arcs in switchgear and the potential damage they cause. The paper responds to conventional protection relay operation in arc fault situations. The paper discusses how different methods of arc protection can be used to limit such damage, and introduces new types of line protection relay with integral arc protection.

INTRODUCTION

Electric arc short-circuits are infrequent switchgear faults where a combination of heat and pressure produce an explosive effect that can cause serious damage to equipment and jeopardize the

safety of operators. Arc protection aims to detect and minimize the burning time of the arc, usually by cutting off the current path feeding the arc by means of detectors connected to a separate, dedicated arc protection unit.

A new type of line protection relay, which incorporates sensor inputs with directly connected arc sensors, can be integrated in the total protection concept at minimal additional cost. An overcurrent relay with integral arc sensor inputs can provide short-circuit and arc protection of a feeder in a switchgear. It will selectively trip the appropriate breaker when an arc fault is detected in the feeder cubicle. In addition, if information about sensor activation is wired to the incoming

feeder's overcurrent relay, the incoming feeder can be tripped when an arc is detected anywhere in the cubicle.

FEATURES OF AN ELECTRIC ARC

An electric arc is formed when current flows from one electrode to another via an ionized gas. Arc phenomenon can be created intentionally, e.g. in an arc furnace or in arc welding. Arcing also happens regularly in normal switching operations.

However, electric arcing is harmful and dangerous, when it happens unintentionally and irregularly e.g. lightning and corona effects. An electric arc which causes a short circuit is the worst possible fault in a power distribution system.

As the temperature in an electric arc

Are you an expert in Arc Flash and Electrical Safety? Your talents are needed NOW!

ELECTRICAL TRAINERS NEEDED

for a variety of subjects:

- Arc Flash Analysis
- Industrial Electrical Safety
- Air Conditioning & Refrigeration
- Short Circuit Study
- Coordination Study
- Arc Flash Study
- Circuit Breaker Testing and Maintenance
- Electrical Relay Protection
- 2006 Canadian Electrical Code
- Power Transformer Maintenance
- Programmable Logic Controllers
- Basic Electricity for the Non-Electrician
- Variable Frequency Drives
- Test and Measurement Equipment
- Boiler Operation, Maintenance & Safety
- Electrical Ladder Drawings, Schematics & Diagrams
- Generators & Emergency Power
- Motors, Controls and Starters

AND

If you have considerable working experience in any of these areas **AND** you have experience in instructing courses in these areas, then send your resume to:
Randolph Hurst,
President,
rwh@rogers.com

The Electricity Forum is one of North America's largest Electrical Training organizations. Since 1986, The Electricity Forum has trained more than 25,000 electrical professionals across North America on a wide range of subjects. Our company is seeking experienced electrical training instructors for our public enrollment and on-site training courses. We offer a competitive and innovative package of training fees and expenses.

The Electricity Forum publishes Electricity Today Magazine, Electrical Source Magazine, and 12 Annual Technical Handbooks. Our website at www.electricityforum.com receives more than 10 million page views a year from 1 Million unique visitors.



rises to about 3000 °C, the air or other gas molecules break down into atoms and then to ions and electrons, which causes the gas to conduct electricity. To make the air this hot and to start an arc, some form of ignition is required such as a thin wire which burns away when current flows through it.

The temperature of a burning arc depends on the fault current, arc voltage and cooling conditions. The centre of the arc may reach 10 000 K to 20 000 K. At contact points it is 3000 K to 4500 K.

At its brightest, the light may be 9000 lux from 6 m to 7 m and last for some 100-200 ms after ignition of the arc, until obscured by smoke and metal vapour. Total radiation may be 1 to 10 W/cm² at a distance of 1.5 meters.

DAMAGES CAUSED BY ARC SHORT CIRCUIT

Energy released from the electric arc can cause damage to equipment and harm to personnel, as well as potential financial losses.

First, the gas is compressed as pressure rises in the enclosed space. When the pressure relief valve opens, the gas expands and flows into the surrounding atmosphere. If this works correctly, the pressure drops in the cubicle and in the room.

Compression and expansion last for 5-15 ms, followed by the radiation phase which last for some hundreds of milliseconds, and the thermal phase which continues until the arc is extinguished.

The burning arc heats the ambient air which expands to create huge pressure inside the switchgear cubicle. At worst, this causes the doors to burst or the whole cubicle to explode, with the added risk of flying debris. Burning gases and hot particles will explode. Electrode materials melt and evaporate. Molten material is splashed everywhere. Busbars and wires may be cut; holes burned in doors, walls or ceilings and equipment destroyed. In addition, the arc



Figure 1: A cubicle damaged by arc short-circuit.

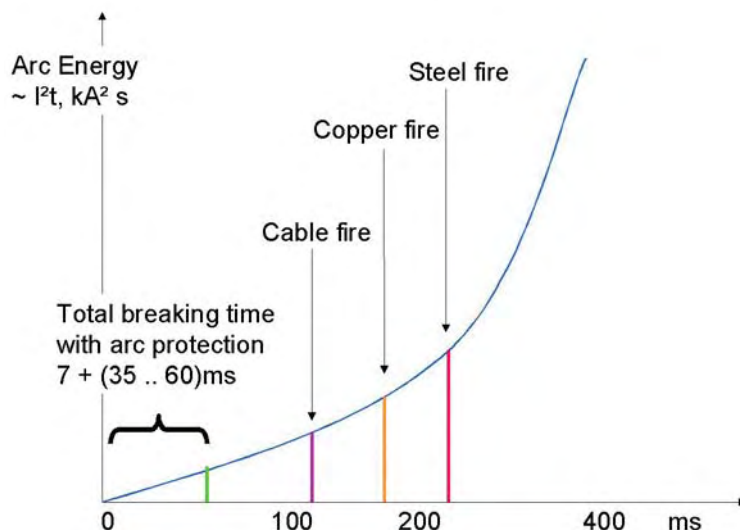

Figure 2: Arc energy as function of burning time. Points where metal parts start to burn are indicated. Arc protection will function before cable fire starts.

may ignite adjacent building materials and cables. Fig. 1 shows damage to a cubicle after an arc short circuit.

Hot or burning gases can injure people whose clothes may catch fire. The gases may be toxic, containing carbon monoxide, and copper or aluminium vapour.

Figure 2 shows arc energy as a function of burning time.

CONVENTIONAL PROTECTION RELAY OPERATION IN ARC FAULT SITUATION

The conventional type of overcurrent relaying does not provide fast enough protection in case of arc faults. This is due to time delayed operation for maintaining the selective operation of the protection, i.e. the upstream feeder protection has to be time delayed in order to coordinate the protection scheme with the downstream feeders. Typically operation time of overcurrent relay in an incoming feeder may be of a range of 100-400 ms, depending on the coordination method (time decaying or blocking based). Additionally breaker opening time has to be considered.

This awkward scenario has been conventionally complemented by applying a busbar differential protection. However, implementing the bus-bar differential protection at the MV level is often impractical due to the cost of the equipment (extra CTs and relays) and complicated and costly engineering. The operation time varies typically from 20 ms

(low-impedance type of protection) to 60 ms (high-impedance type of protection). Additionally, breaker opening time has to be considered.

Furthermore, in case of resistance earthed networks the high-impedance type of arc ground faults may cause problematic and dangerous situations. As the arc fault in many cases starts as 1-phase fault only then converting to the phase-to-phase fault, the conventional ground fault relay time delay is typically set so that the fault is only cleared by the phase overcurrent relay. This scenario may lead to long arc burning time and, therefore, may jeopardize the operational safety of the installation.

LIMITING THE DAMAGE

Damage can be limited by improving switchgear construction, e.g. by using the correct design of pressure vents and channels, by dividing the switchgear into smaller cells and by testing. Poisonous gases must be safely evacuated and emergency exits should be readily accessible. Personal protective equipment (PPE) is widely used in order to mitigate personal injuries.

The best way to reduce damage from an arc shortcircuit is to limit arc burning time, i.e. the total time required to detect the arc and stop the current flow. As a rule of thumb:

- 35 ms: no significant damage to people or switchgear – insulation

should be checked

- 100ms: minor damage – may require cleaning and minor repairs
- 500ms: serious harm to people, and to switchgear which must be partly replaced.

Tripping the breaker which feeds the arc current effectively limits both direct and indirect damage.

ARC DETECTION

Arc protection must first detect an arc and then cut the flow of current, usually by opening a circuit breaker. Another possibility – especially in low voltage systems – is to cause an intentional galvanic short-circuit to drain off the current flow and thereby extinguish the arc.

Because arcing is accompanied by radiation, its presence can be detected by analyzing visible light, acoustic waves, infrared or radio frequency radiation or even the pressure wave it causes. However, the most common method of detection is visible light (Fig. 3). The presence of short-circuit current together with one of the above indications is usually required before making an arc short-circuit trip.

To ensure rapid operation of the arc protection system in case of high-impedance type of faults, it is also essential to measure the neutral current. A suitable sensitive setting is desired for detecting this type of ground fault. The operation is then based on simultaneous light and phase overcurrent or ground overcurrent conditions. In this way the arc ground fault is cleared even before it has converted to phase-to-phase fault.

ARC PROTECTION WITH DEDICATED DEVICES

Arc protection is usually implemented by a separate system using arc detectors directly connected to dedicated arc protection units. Line protection is implemented by standard protective relays.

These devices (Fig. 4) usually comprise arc sensors (photo transistors or fibre optic loops), slave units to collect data from the arc sensors, and a master unit for final collection of all the arc sensor data, measuring the current and tripping the breaker, if both overcurrent and light are detected.

Such a system opens the main breaker when an arc shortcircuit is detected. If the switchgear contains two or more zones separated by breakers, the system can be built to open only the breaker in

the faulty zone and the breaker(s) separating the zones. Fig. 5 shows an arc protection system with two protection zones using two master units (VAMP) and multiple slave units (VAM). If a fault is detected e.g. in zone 1, then breakers CB1 and CB5 will be opened.

In multi-zone arrangements, master units must be able to interchange data. Information about an activated arc sensor can be distributed to all master units so that all master units which detect overcurrent can open the circuit breakers in their zones. Similarly, information about locally detected overcurrent can be

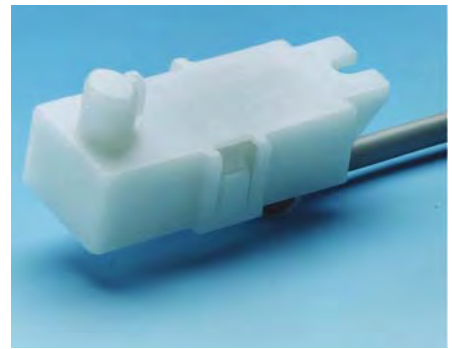

Figure 3: Light sensor for detecting electric arc.

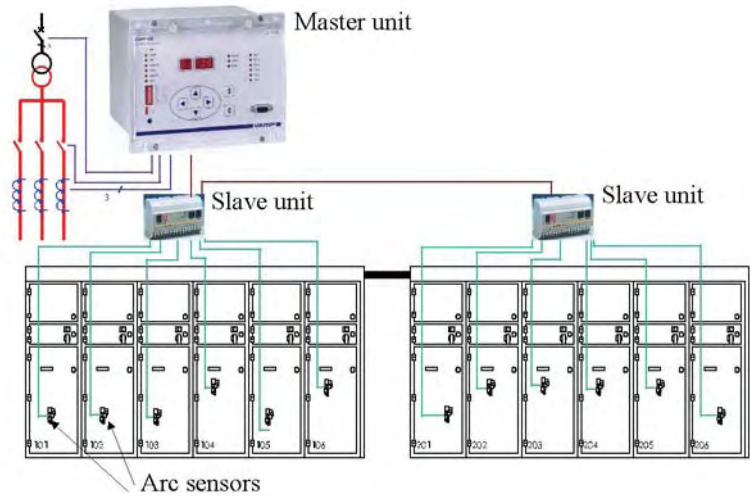

Figure 4: Structure of an arc protection system.

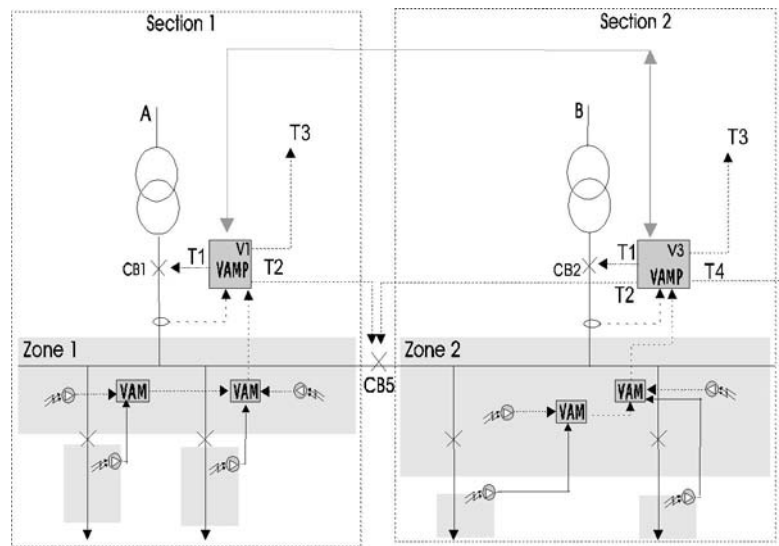

Figure 5: Arc protection system with two protection zones implemented with two master units (VAMP) and multiple slave units (VAM). If fault is detected e.g. in zone 1 then breakers CB1 and CB5 will be opened.

passed to other units as a trip condition, if one unit detects light but no overcurrent.

The fault clearing time is typically 7 ms + the breaker opening time.

INTEGRATED ARC PROTECTION

A new type of protection relay can be equipped with arc sensor inputs to which the arc sensors are directly connected, so that arc protection is integrated as part of the total protection concept at minimal additional cost. The arc sensor input may include e.g. two inputs for arc sensors, one binary input and one output for receiving/sending arc sensor data to other relays. The relays include high-speed overcurrent and earth-fault stages dedicated to operation with the arc sensors.

Increased selectivity of the arc protection system

The selectivity of arc protection is increased if the arc sensors of an outgoing feeder are connected to its overcurrent relay (Fig. 7). If an arc fault occurs in the feeder area, only the breaker of the feeder in question is opened and the rest of the substation remains operational. The main arc protection system opens the incoming breaker only if there is an arc shortcircuit in an area where outgoing feeders cannot measure shortcircuit current.

Arc sensors (Arc1 and Arc2 in Fig. 7) should be installed in the cable chambers of the outgoing feeder cubicles. Arc sensors connected to the main arc protection system (e.g. Arc3 and Arc4) would be installed in the truck and busbar chambers.



Figure 6. An overcurrent relay with intergrated arc protection.

Adaptive arc protection

Fig. 7 shows part of a switchgear where power is normally fed through the transformer but, in special situations, power may also be brought in via an outgoing feeder. Normally the overcurrent relays take care of feeder arc protection and the arc protection relay protects the busbar section. If power is fed in through one of the normally outgoing feeders, the overcurrent relay of that feeder is also used to provide arc protection.

This is possible because information about arc sensor activation can be brought to the overcurrent relay by the binary outputs and inputs. The arc protection function of the overcurrent relay will trip the breaker whenever it measures arc short-



VAMP

Protection Relays

Preventing on-site injuries in a FLASH



Electric Arc Incidents can and do occur at anytime. Apply a fast acting, world leading protection technology in your new or existing electrical equipment that will greatly reduce the harm and damage to personnel and equipment.

www.vamp.fi

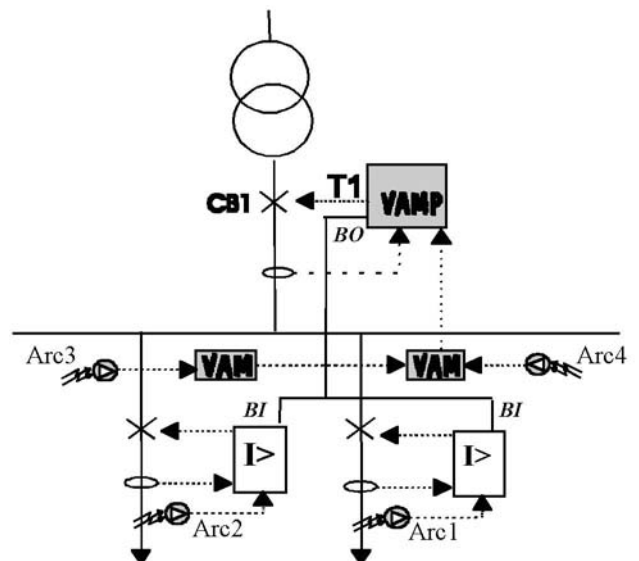

Figure 7: Overcurrent relays with arc sensor option and specialised arc protection system (VAMP and VAM). Information about activation of arc sensors Arc3 and Arc4 is also brought to the overcurrent relays via the binary inputs (BI).

circuit current and either its own or one of the other switchgear sensors (Arc3 and Arc4 in Fig. 7) detects an arc.

The fault clearing time is typically 15 ms + the breaker opening time.

Cost-effective arc protection

Fig. 8 shows that a low-cost arc protection system can be built using protection relays with arc sensors. Information about activated arc sensors is transferred between the relays using binary inputs and outputs. The relay trips if it detects overcurrent and at the same time its own arc sensor or one of the arc sensors of the other relays is activated. However, the coverage of this type of system is limited because the number of arc sensors is limited.

AN EXAMPLE OF AN INSTALLED SYSTEM

Protective relays with integrated arc protection have been installed e.g. to the Rautaruukki Steel in Finland. Figure 9 shows a switchgear panel including an overcurrent relay with integrated arc sensors. Figure 10 shows an arc sensor attached to the wall of a cubicle. There is a hole in the wall of the cubicle through which the sensor is looking inside it. Figure 11 shows arc sensors attached on top of an open switchgear.

CONCLUSIONS

The conventional type of overcurrent relaying is not able to isolate arc short-circuits quickly enough to avoid the damage to switchgear. Time delays due to protection coordination and high-impedance type of faults cause prolonged operation times for the conventional type of relaying. Arc protection, either with dedicated devices or integrated in a protection relay, is a vital part of switchgear protection due to the potentially drastic damages caused by arc shortcircuits.

Adding an arc sensor option to standard protection relays provides new possibilities in levels of arc protection. Such protection can either be implemented at minimal cost or the selectivity, flexibility and scope of arc protection can be increased.



Figure 9. VAMP 140 relay installed at Rautaruukki.



Figure 10. An Arc sensor installed at wall of a cubicle.



Figure 11. Arc sensors attached on top of an open switchgear.

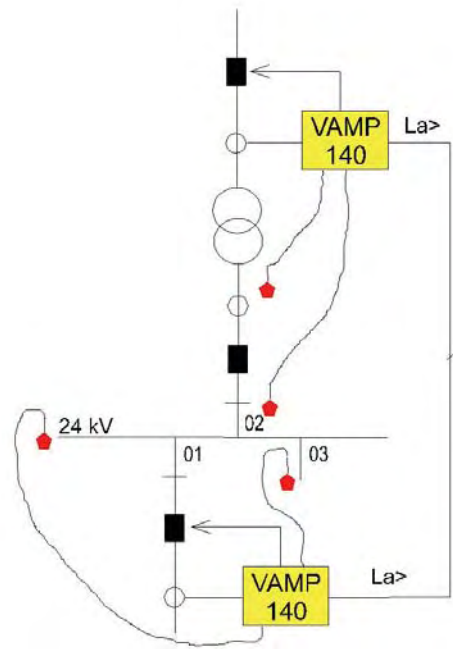

Figure 8: Arc protection system using overcurrent relays with arc sensor option. Information about the activation of the arc sensors may be carried between the relays using the binary inputs and outputs (La>).

“We are buying: Surplus Caterpillar and Waukesha engines and generator packages, diesel or natural gas, complete or parts, large or small.

Call or write with description to:

CAPROCK EQUIPMENT INCORPORATED

PHONES
432.362.3131
800.267.1378

FAX/E-MAIL
423.362.2304
caprock1@netwest.com

MAIL
P.O. Box 14288
Odessa, Texas 79768

SHIP
8326 N. County Road West
Odessa, Texas 79764